

**TB370**  
**7-TONNE**



**POWERFUL  
COMPACT EXCAVATOR**

**3** SERIES

**TAKEUCHI**<sup>®</sup>  
From World First to World Leader

# NEW 3-SERIES TB370

## 7-tonne excavator

The TB370 combines all the proven characteristics of Takeuchi excavators: smooth hydraulics and power performance, proven durability, high resale value, with maximum operator comfort and serviceability.

The TB370 is from the New 3-SERIES of Takeuchi excavators, packed full of value-added features offered as standard for maximum safety, operator comfort and productivity.



### TURBO POWER & LOW EMISSIONS MAXIMUM BREAKOUT FORCE & REACH

The TB370 meets all the very latest low emission standards with a low noise Stage V compliant engine.

The TB370 turbo charged engine combined with the Kawasaki hydraulic pump gives excellent efficiency and precise feel to the operator.

The TB370 offers massive breakout force of 48.4kN for a 7-tonne excavator and maximum operating parameters: ground level reach of 6565mm, digging depth of 4085mm and dump height 4545mm.

**STAGE V**  
**COMPLIANT**

### MAXIMUM FUEL EFFICIENCY

Fuel Saving Features:

- Automatic idle
- Economy work-mode
- Electronic engine monitoring
- Electric dial throttle control
- Two-speed tracking with auto step down
- TFM - Remote utilisation data





### ENHANCED FEATURES AS STANDARD

A rear-view HD colour camera with split screen and auto-reverse activation for maximum visibility on busy sites.

Accumulator assisted pilot controls combined with cushioned boom, arm and swing cylinders, help reduce shock and vibrations for a smoother machine operation.

The TB370 comes factory fitted with steel hydraulic hitch pipework and with safe hand/foot activation switches. Dual flow hydraulic lines operated by sliders on both levers, for smooth control of variable flow and detent to accommodate a wide range of attachments.

Auxiliary flows and pressures are adjustable from the touchscreen control with optional password secure presets.



### TSS - TAKEUCHI SECURITY SYSTEM

The TB370 comes with **TSS** as standard. Includes 1 red master key and 3 black user keys. Can programme up to 13 user keys.



### TFM - TAKEUCHI FLEET MANAGEMENT

**TFM** is a remote **TELEMATICS** system, using real time data to better manage your fleet and lower overall operating costs. Free of charge in warranty period.

## ROBUST SITE PROTECTION

Cast steel wraparound counterweight and 100% all steel panels provide robust protection.

Boom and arm holding valves are factory fitted for added safety in the event of a hose burst failure. An audible warning lift alarm is standard for craning.

The hydraulic hoses are well-positioned to prevent damage. Cushioning on the heavy-duty boom, arm and swing cylinders improves component longevity.

Enhanced blind side visibility via the larger and lower offside window.

All around well protected LED workzone lights and 4 blind spot mirrors enhance on-site visibility along with side-step delayed courtesy lighting.



## REDUCED TAIL SWING

The compact TB370 features a shorter than average tail swing compared to conventional 7-tonne excavators.

Just 1480mm and therefore 455mm overhang at 90° to track and rounded corners helps to minimise potential machine damage in restricted areas.



## COMPATIBLE BREAKER

The TB370 is compatible with a Takeuchi TKB302-S sound suppressed hydraulic breaker. Designed to meet the requirement for quieter operating environments.

## RELIABLE TRACK DESIGN

Triple flanged rollers support the track in multiple positions improving machine stability. The upper roller maintains track alignment and helps shed debris.

High torque auto step-down travel motors deliver on-demand tracking power when dozing, turning and climbing.



## SWITCH ACTIVATED BLADE FLOAT

To maximise ground finishing on-site the switch activated blade float is fitted as standard

A heavy-duty dozer blade with a blade cylinder protection guard.

Exposed ground level hydraulic hoses are spiral steel wrapped for added protection.

## STANDARD FEATURES

(see website for the complete features list)

### OPERATOR STATION

- All steel tilting Cab (ROPS/ OPG)
- Adjustable deluxe heated highback seat with retracting seat belt, drinks holder and adjustable armrests
- AC/ climate control/ heater/ de-mister
- Gas-strut lift-assist window slides into recess
- Skylight with sunshade and rain guard
- Radio - stereo speakers DAB/ Bluetooth/ and microphone sockets
- Rear-view HD colour camera with split screen
- Steel folding foot travel pedals

### ELECTRICAL

- 8" colour touchscreen VDU
- Multi-switch control panel and jog dial
- 12V/USB in-cab power sockets
- Switched roof beacon power socket - 12V
- All around LED workzone light package
- Travel alarm
- Emergency engine shut-down switch
- Electrical refuelling pump - retractable

### ENGINE

- DOC+DPF exhaust after treatment
- Dual fuel filtration - water trap sensor
- Automatic idle
- Service interval - 500 hours
- Working modes: Standard/ Eco/ Altitude



### HYDRAULICS

- Cushioned boom, arm and swing cylinders
- Boom and arm holding check valves
- Lift overload alarm
- Aux flows/ pressure - touchscreen adjustable
- Multi-attachment presets - password secure
- 1st and 2nd autotank and pressure release
- Aux with independent isolation valves
- Proportional auxiliary controls with detent
- Aux ports: 1st + 2nd standard, 3rd (pre-piped for hydraulic hitch)

### UNDERCARRIAGE AND FRAME

- Dozer with switch activated blade float
- Triple flanged track rollers & sealed bearings
- Secure-sure anchor points



# TB370 POWERFUL COMPACT EXCAVATOR



## MAXIMUM ALL DAY COMFORT

The TB370 has a large cab with excellent operator functionality and all around visibility with ROPS/OPG that gives the operator maximum safety.

The large adjustable heated highback air-suspension seat provides maximum comfort for a full working day. The tool-free adjustable armrests cater for different operating positions.

The cab has plenty of foot room and an extended foot pedal gives operators added control. Maximum comfort comes with air-con climate control and a gas lift-assist retractable front window, with removable / stowable lower glass.

Extra cab features include a large skylight with sun-shade and a rain guard for open window operating. Electrics include DAB radio, Bluetooth, and 12V USB power socket.

The TB370 features the latest automotive styled Jog-Dial, for easier ergonomic control.

The 8" colour touchscreen VDU turns horizontal / vertical for operator preference and illuminates all active operating switch functions including: lift overload, power altitude, auto idle, auxiliary detection and the rear-view HD camera.



## MAXIMUM SERVICEABILITY

The TB370 features a functional tilt-up cab that gives full access to the control valves, hydraulic pipework and rear engine components. The styled all-steel engine hood and off-side service panel gives unparalleled access to engine and hydraulic components.

- Easier machine maintenance, all accessible at ground level.
- Hydraulics and fuel sight gauges are easily visible.
- Compactly stored away is the fast-filling retractable electric refuelling pump, with auto shut off and suction filter for added safety when refuelling.



# TB370 POWERFUL COMPACT EXCAVATOR



All measurements are in mm.  
Mono Boom (2-piece boom)

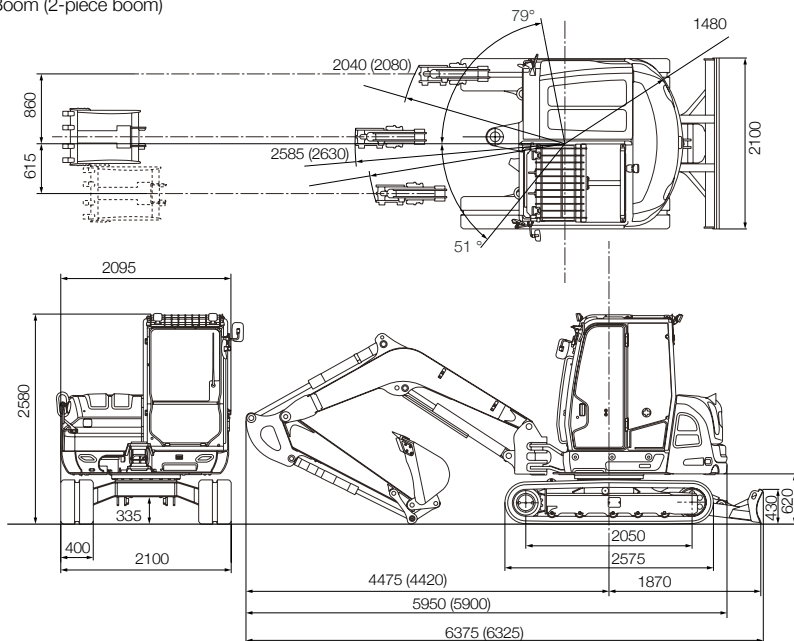

Mono Boom

2-piece boom

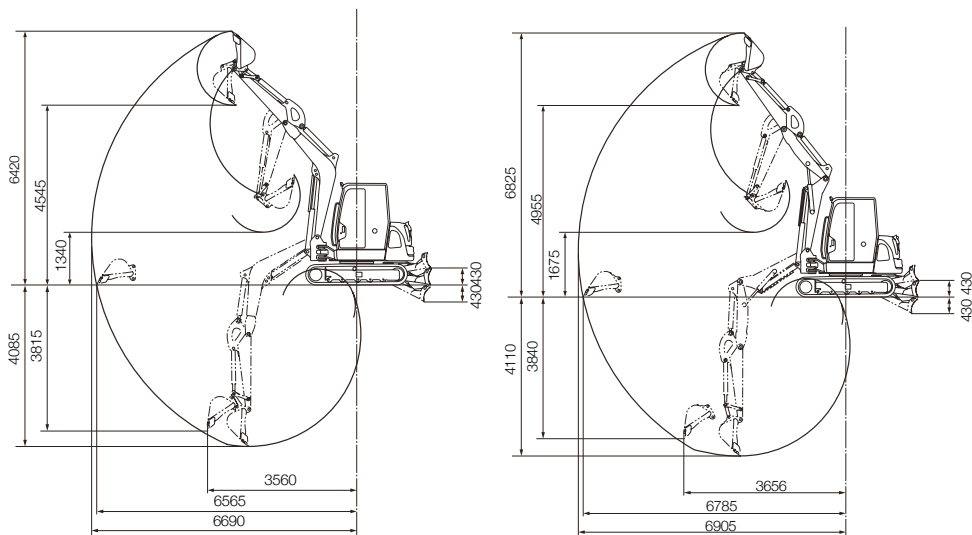

**2 YEAR  
2,000 HOUR**

**WARRANTY**

Takeuchi machines come with a 2 year/2000 hour warranty as standard.

Before fitment of a hydraulic attachment, machine auxiliary pressure and flow should be accurately measured. For all lifting specifications please refer to the lift charts on the Takeuchi website or operator manual.

In accordance with our established policy of constant improvement, we reserve the right to amend these specifications at any time without notice. Photographs shown may feature non-standard equipment.

## TB370

Standard UK Spec – Long-Arm Mono Boom - Rubber Tracks  
Optional: Steel Tracks - (2-piece Boom)

Engine	
Make	Kubota
Model	V2607-CR-TE5B
Rated Output (kW)	42.4/2000
Maximum Torque (Nm)	213.4
Cylinders	4
Displacement (cc)	2615
Electrical System	12v 90A

Dimensions & Weight	
Op. Weight (bucket, hitch, fuel) kg	7001 (7065)
Long-Arm (2-piece)	
Length (Transporting) (mm)	5950 (5900)
Long-Arm (2-piece)	
Width (mm)	2100
Height (mm)	2580
Ground Clearance (mm)	335
Dozer Blade (W x H) (mm)	2100 x 430

Operating Information	
Max Digging Depth (mm)	4085 (4110)
Max Dump Height (mm)	4545 (4955)
Max Reach at Ground Level (mm)	6565 (6785)
Max Vertical Dig Depth (mm)	3815 (3840)
Max Bucket Digging Force (kN)	48.4
Max Arm Digging Force (kN)	29.4 (31.7)

Hydraulic System	
Main System Pressure (bar)	245
Pump Type	Kawasaki Var x 2 Gear x 2
1st Auxiliary Maximum Flow (l/min) / Pressure (bar)	120/206
2nd Auxiliary Maximum Flow (l/min) / Pressure (bar)	46/206

Swing System	
Slew Radius (mm)	1480
Slew Speed (rpm)	8.8
Slew Motor	Constant Volume Piston
Slew Brake	Wet Friction Plate

Undercarriage	
Traction Motor	Axial Piston
Traction Drive	Planetary
Traction Brake	Disc
Track Width (mm)	400
Ground Contact Length (mm)	2050
Ground Pressure (kpa)	37 (39)
Travel Speed (km/h)	2.5 - 4.7
Maximum Gradeability	30°

Capacities	
Hydraulic System (l)	139
Fuel Tank (l)	110
Engine Lubrication (l)	9
Cooling System (l)	11

Health & Safety	
Noise / Sound Power Level (LwA)	95 dB
Vibration Hand Arm / Body m/sec <sup>2</sup>	≤2.5 / ≤0.5

4/2024

For more information locally contact:



SCAN ME

To find your local dealer

Takeuchi Mfg (UK) Ltd, Unit E2B Kingsway Business Park,  
John Boyd Dunlop Drive, Rochdale, Lancashire OL16 4NG  
info@takeuchi-mfg.co.uk www.takeuchi-mfg.co.uk

@TakeuchiUK

**TAKEUCHI**  
From World First to World Leader